

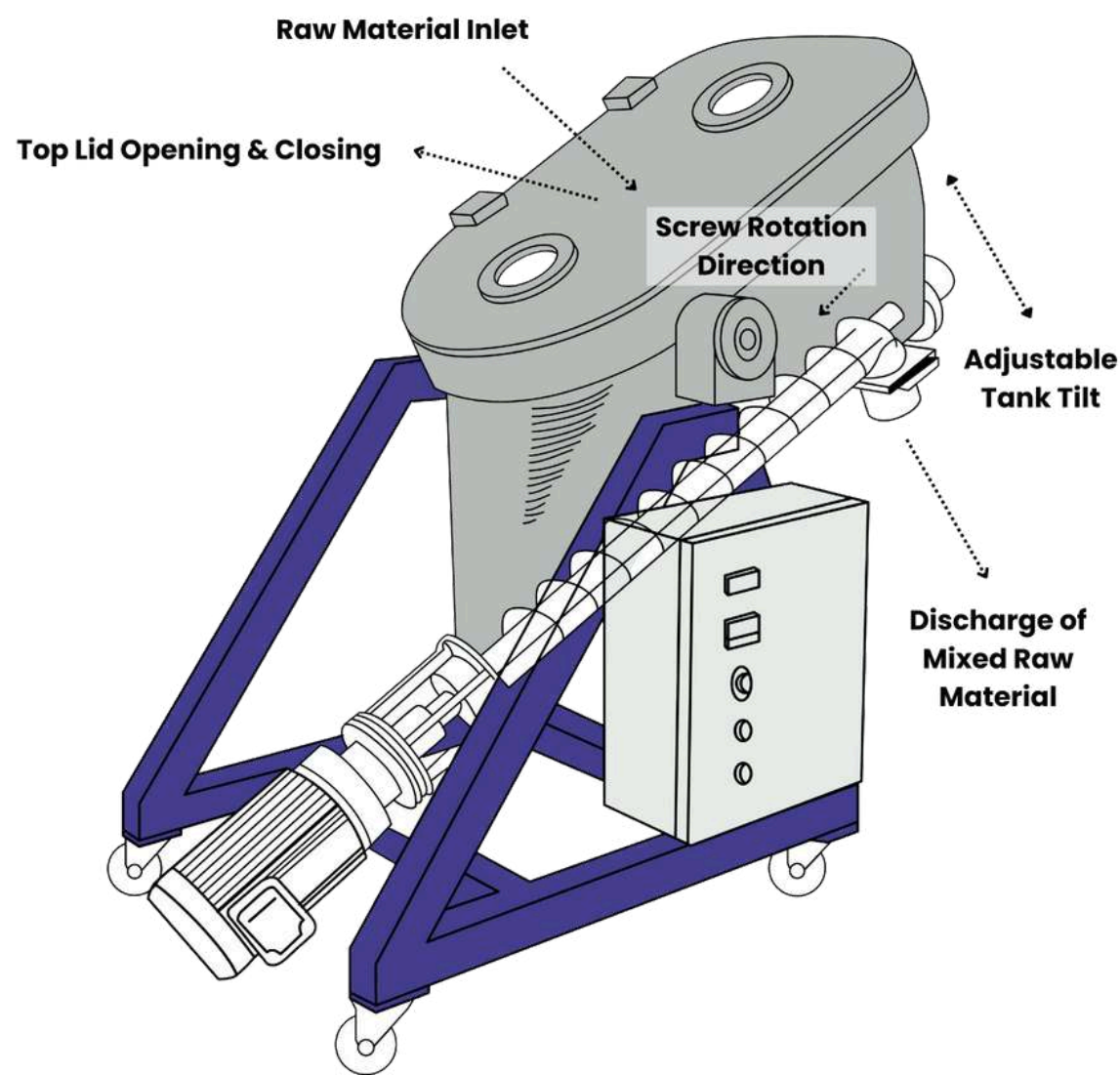

# SCREW BLENDER

High-Speed, Uniform Mixing, and  
Energy-Efficient





# High-Speed, Uniform Mixing, and Energy-Efficient Blender!

Our blender achieves uniform mixing in just 2-3 minutes for pellet-based materials and 4-5 minutes for powder-based materials, significantly reducing mixing time. It offers automatic operation, ensuring superior safety and ease of use, with an inverter control for easy adjustment of rotation speed. Energy-efficient and heat-free, it is an economical and eco-friendly choice.

#Peripheral

## Versatile Screw Blender for Chemical to Recycling Applications!

Our screw blender is ideal for the chemical, food manufacturing, pharmaceutical, construction, and recycling industries. Its high-speed mixing, compact design, and automatic operation support efficient and uniform product production.

Specification	SB-100	SB-200	SB-300	SB-500	SB-800	SB-1000	SB-1200	SB-1500
Tank Capacity / l	100	200	300	500	800	1000	1200	1500
Drive Motor / kW	2.2	3.7	5.5	7.5	11	11	15	18.5
Screw Rotation Speed / rpm	300	300	300	300	300	300	300	300
Length L / mm	1650	2050	2350	2700	3000	3200	3400	3700
Width W / mm	900	1130	1250	1450	1650	1780	1900	2000
Height H / mm	880	1100	1250	1700	1800	1950	2000	2200
Machine Weight / kg	250	300	340	400	620	780	900	1150



# Creative Technology & Extruder

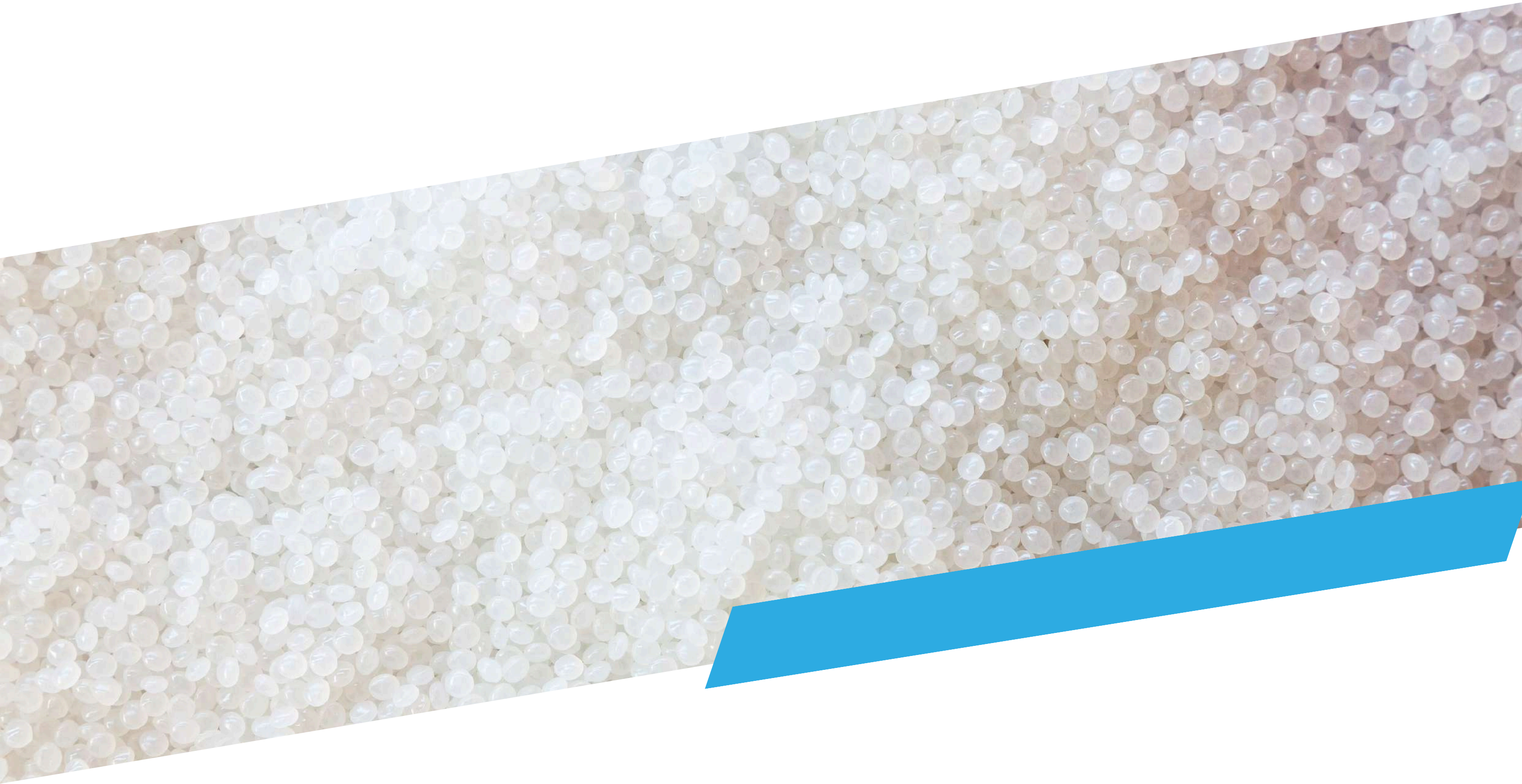

**Get In  
Touch**



[www.cte-japan.com](http://www.cte-japan.com)  
Open QR codeをクリックしてください

**cte**

**株式会社シーティーイー**  
**CTE Co., Ltd**

〒362-0032 埼玉県上尾市日の出 3-4-5  
3-4-5 Hinode, Ageo City, Saitama 362-0032, Japan

TEL: 048-778-0393 / FAX: 048-778-0394  
Email: [info@cte-japan.com](mailto:info@cte-japan.com)